

Features
AIO 4IN1 Crazybee F4 Lite flight controller built-in 5.8G VTX
Extreme light 1S 65mm Brushless HD whoop only 27g
Come with Runcam Split3-lite 1080P HD DVR
Smooth and agile
Compatible for 1S Lipo/LiHV
Camera Angle adjustable

Specifications
Brand Name: HappyModel
Item Name: Mobula6 HD 1S 65mm Brushless whoop HD drone BNF version
Wheelbase: 65mm
Size: 80mm*80mm*40mm
Weight: 27g
Receiver option:
Internal SPI Frsky version (Compatible with ACCST D8/D16, Recommend D8 mode)
Internal SPI Flysky version(Compatible with AFHDS and AFHDS-2A Flysky transmitter)
External DSM2/DSMX version(Compatible with Spektrum DSM2/X transmitters)
External TBS CRSF NANO version(Compatible with TBS ransmitters)

Package includes

Item Name	Qty
Mobula6 1S 65mm whoop Drone Frame	1
SPI Receiver Option1: Crazybee F4 Lite FC built-in Frsky SPI D8 RX	
SPI Receiver Option2: Crazybee F4 Lite FC built-in Flysky SPI RX	1
External receiver option1: DSM2/DSMX compatible satellite receiver	
External receiver option2: TBS CRSF NANO receiver	
EX0802 KV19000 brushless motor	4
Gemfan 1219-3 Propellers(4cw+4ccw)	1
Runcam Split3-lite 1080P HD Camera + DVR	1
5.8G 25mw 40ch vtx (Flight controller built-in)	1
1S 250mah 30C LiHV Battery	4
1S Lipo/LiHV USB Charger	1
Propeller disassemble tool	1

Flight controller connection diagram

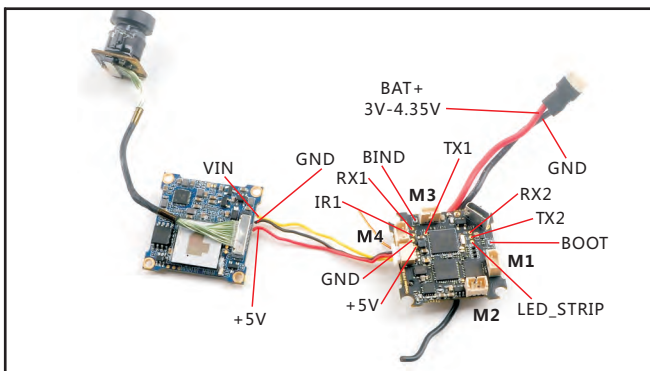
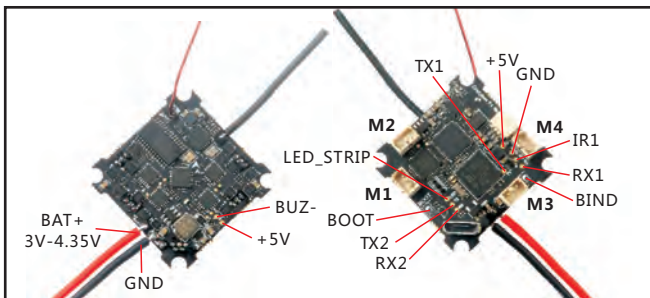

Binding procedure

1.Powering the Mobula6 HD then the red LED at the bottom of the flight controller will blinking slowly. And then press the bind button ,the red led will getting to be solid ,this indicate the receiver is in bind mode.

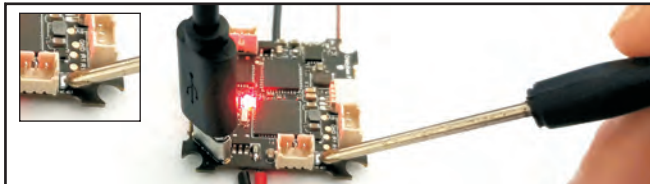

Another simple way to bind with the Frsky transmitter is : Plug the usb and go to the CLI command tab in the betaflyght configurator, then type "bind_rx_spi"(compatible with Betaflight 4.0.x fimware) or type "bind_rx"(compatible with Betaflight 4.1.x firmware),the receiver will getting into bind mode , and then make your Frsky transmitter to bind mode.

```

$M>?e?000:00000000 000000000000$M> n0000000000e
Entering CLI Mode, type 'exit' to return, or 'help'

# bind_rx_spi
Binding..
    
```

2.Turn on your Frsky Taranis transmitter, and move to BIND OPTION from SETUP MENU, Choose receiver mode D16 or D8 according to your Betaflight receiver configuration (Frsky_X = D16 mode, Frsky_D=D8 mode)we recommend use D8 mode



3.ENT [Bind] to binding with the Mobula6 HD ,the red LED at the bottom of the flight controller will blinking slowly ,this indicate binding successfully, and then exist binding mode of your Frsky transmitter, the red LED at the bottom of the flight controller will getting to be solid again, this indicate working normal.

Receiver configuration

Please set Receiver mode to be SPI RX Support from the Configuration tab of the Betaflight Configurator, then select FRSKY_X Provider for FRSKY D16 MODE or Select FRSKY_D Provider for FRSKY D8 MODE, don't enable Serial RX since the CRAZYBEE Flight controller is integrated SPI BUS Receiver

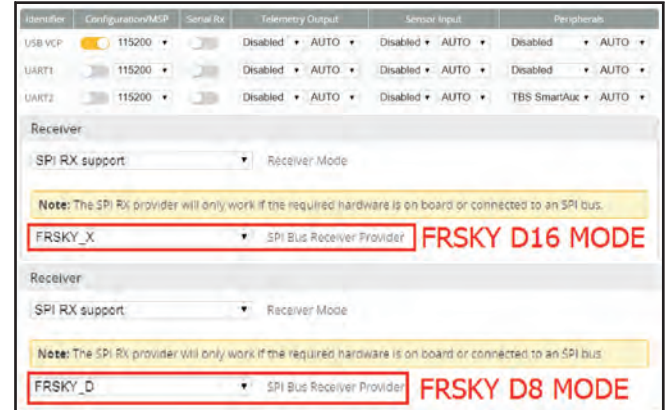

If you want to use "Frsky_x_lbt" or Futaba "S-FHSS" protocol ,please upgrade the betaflyght firmware to 4.0.x or 4.1.x

Arm/Disarm the Motor

1. The Default Arm/Disarm switch for Mobula6 HD is AUX1(Channel 5),and you can also customize it with Betaflight Configurator.



2.Turn on the Frsky transmitter (Use X9D+ as an example) and move to the MIXER interface, Set "SA" or "SB" switch etc. for Ch5 to ARM/DISARM the motor.



3.The default channel map for Mobula6 HD Frsky version is TAER1234, please make sure your transmitter is matched, otherwise it will can't be armed. Toggle the AUX1 Switch ,the Green LED on the flight controller will getting to be solid, this indicates the motor was armed . And also you can found "Armed" displayed on your FPV Goggles or the FPV Monitor. Please make sure keep the Mobula6 HD level before arming .Be careful and enjoy your flight now !

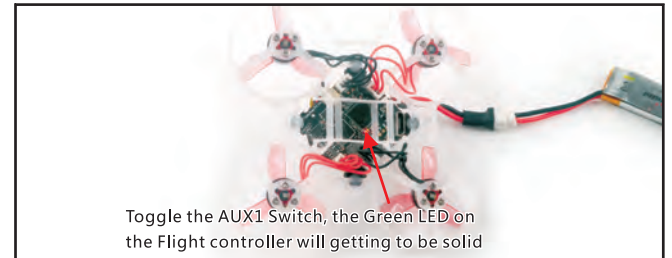

VTX Bands and Channels setup

Frequency and channel frequency table:

FR \ CH	CH1	CH2	CH3	CH4	CH5	CH6	CH7	CH8
Band1(A)	5865M	5845M	5825M	5805M	5785M	5765M	5745M	5725M
Band2(B)	5733M	5752M	5771M	5790M	5809M	5828M	5847M	5866M
Band3(E)	5705M	5685M	5665M	5665M	5665M	5665M	5905M	5905M
Band4(F)	5740M	5760M	5780M	5800M	5820M	5840M	5860M	5880M
Band5(R)	5658M	5695M	5732M	5769M	5806M	5843M	5880M	5917M

There are 2 ways to switch the vtx channels:

- If we need to use Channel 5705 then we should Go to Betaflight CLI, type the command:
Set VTX_band=3
Set VTX_channel=1
save
- Disarm the Mobula6 HD and then move the stick of the transmitter (THR MID+YAW LEFT+PITCH UP) to enter OSD Menu, Enter to Features, then enter to VTX SA to set VTX Band and channel

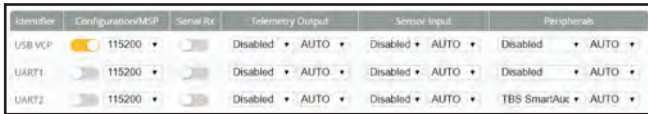

Mixer type and ESC/motor protocol

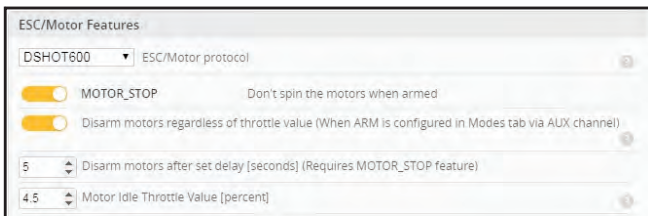
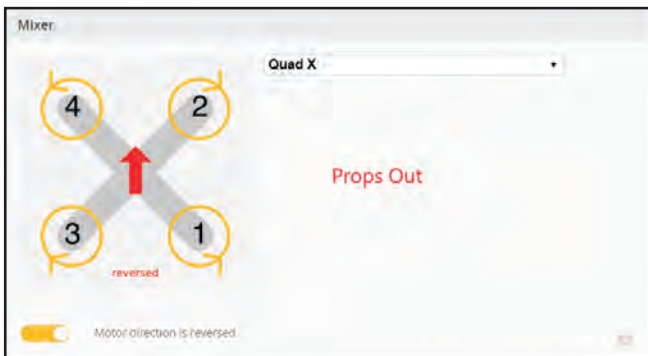

Default PID setting

Axis	Proportional	Integral	Derivative	Feedforward	RC Rate	Super Rate	Max Vel (deg/s)	RC Expo
ROLL	80	25	80	100	1.00	0.70	667	0.00
PITCH	80	25	80	100	1.00	0.70	667	0.00
YAW	90	90	0	100	1.00	0.70	667	0.00

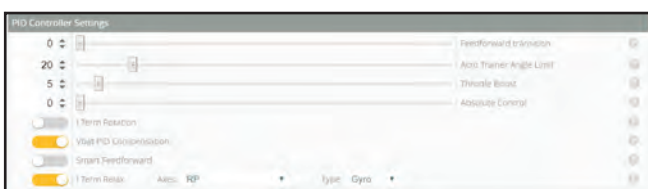

Note: "ESC Check and flash firmware" and "Flight controller firmware update" procedure are not necessary. The procedure at the right side is just a tutorial to show how to do it. We already pre-install firmware and pre-configure the ESC and the flight controller.

ESC Check and Flash firmware

- Download New release BLhelisuite from: <https://www.mediafire.com/folder/dx6kfaa5yo24i/BLHeliSuite>
- Plug the usb and connect the flight controller to computer



- Open the Device Manager of your computer, find the Ports, please make sure the Com port Serial Number is under 255, otherwise it will can't connect to the BLHELISUITE. You can change the port serial number like the following step:

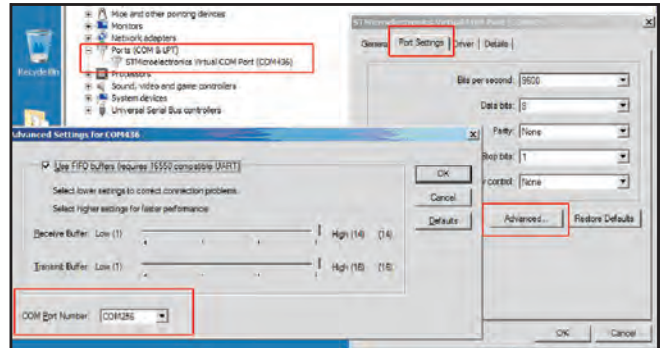

- Open the BLHELISUITE, Select SILABS BLHeli Bootloader (Cleanflight) from the third tab on the top side. Then Select the right Serial com port and Click connect. You can also Flash the new release BLHeli_s firmware via the BLHELISUITE, the firmware Target is "O-H-05"

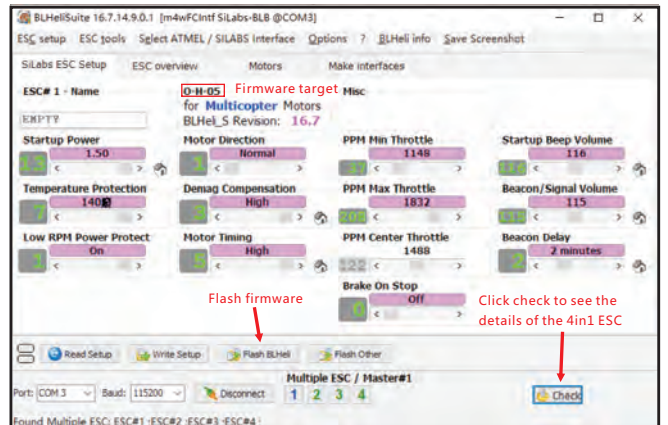

Flight controller firmware update

- Install latest STM32 Virtual COM Port Driver <http://www.st.com/web/en/catalog/tools/PF257938>
- Install STM BOOTLOAD Driver (STM Device in DFU MODE)
- Open Betaflight configurator and choose firmware target "CRAZYBEEF4FR(LEGACY)", then select the firmware version.
- There are 2 ways to get in DFU Mode: 1). solder the boot pad and then plug USB to computer 2). loading betaflight firmware and hit "flash", then it will getting into DFU Mode automatically.
- Open Zadig tools to replace the drivers from STM32 Bootloader to WINUSB Driver.
- Reconnect the flight controller to the computer after replace driver done, and open Betaflight Configurator, loading firmware and flash.

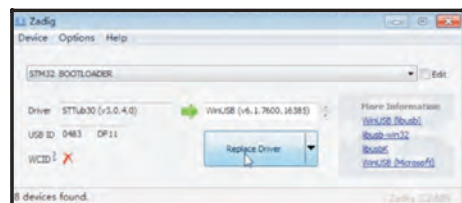

"Flip over after crash" procedure

Set one channel of your radio transmitter to activate the Flip over function in the Mode tab of Betaflight configurator. The default Switch for Activate "Flip" is AUX4(Channel8)

